

Code No: 152AP

JAWAHARLAL NEHRU TECHNOLOGICAL UNIVERSITY HYDERABAD

B. Tech I Year II Semester Examinations, May - 2019

BASIC ELECTRICAL ENGINEERING

(Common to EEE, CSE, IT)

Time: 3 hours

Max. Marks: 75

Note: This question paper contains two parts A and B.

Part A is compulsory which carries 25 marks. Answer all questions in Part A. Part B consists of 5 Units. Answer any one full question from each unit. Each question carries 10 marks and may have a, b, c as sub questions.

PART - A**(25 Marks)**

- 1.a) State the KCL. [2]
- b) Define the RMS value of a sinusoidal quantity. [2]
- c) List the various losses in the transformer. [2]
- d) What are the different speed control methods of induction motor? [2]
- e) What are the types of cables? [2]
- f) States the Norton's theorem. [3]
- g) What are the merits of polyphase system? [3]
- h) Draw the different connection diagrams of three phase transformer. [3]
- i) Why single phase induction motor is not self starting? [3]
- j) What are the important characteristics of batteries? [3]

PART-B**(50 Marks)**

- 2.a) Define the electrical circuit elements.
- b) For the circuit shown in figure 1, find the current flowing in all the branches. [5+5]

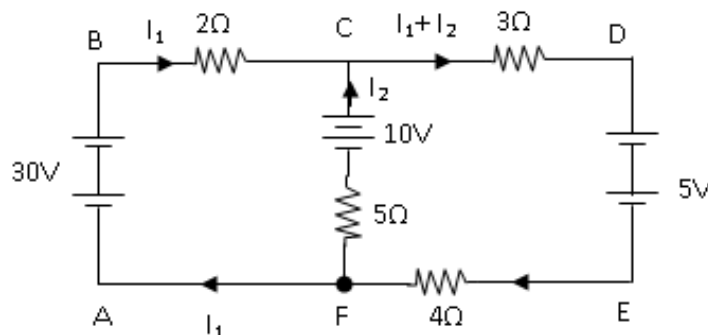
**Figure: 1****OR**

3. Using superposition theorem calculate the current in 8 ohms resistances shown in following figure 2 (All resistance are in ohms). [10]

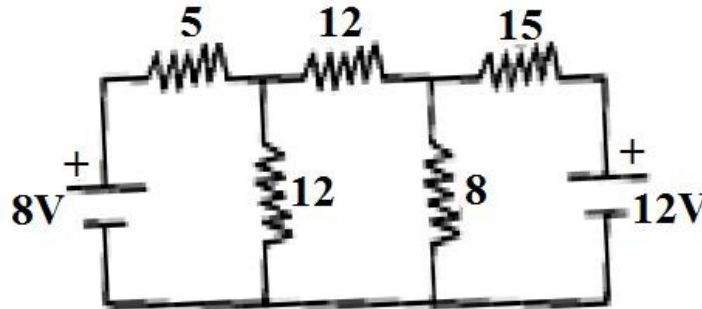

Figure: 2

4. An inductive coil consisting of a resistance of 3.1Ω and an inductance of 0.04 H is connected in parallel with a non inductive resistor of 15Ω across 240 V , 50 Hz supply. Determine the following:
 a) Current in each branch,
 b) Power absorbed by the inductive coil
 c) Total current drawn from the supply and
 d) Power factor of the circuit as a whole. Draw to scale the phasor diagram of the circuit. [10]

OR

- 5.a) Derive the resonance frequency of series circuit in terms of half power frequencies.
 b) Derive the relation between line and phase quantities of voltages and currents for a star connected system. [5+5]
- 6.a) Derive the expression for the EMF equation of a single phase transformer.
 b) A 20 kVA , single phase transformer has 400 turns on the primary and 250 turns on the secondary. The primary is connected to 1000 V , 50 Hz Supply. Determine i) The secondary voltage and ii) The maximum value of flux. [5+5]
- 7.a) What is a transformer? How does it transfer electrical energy from one circuit to another?
 b) A 30 kVA , $200/120 \text{ V}$, 50 Hz transformer has a high voltage winding resistance of 0.1 ohm and a leakage reactance of 0.22 ohm . The low voltage winding resistance is 0.035 ohm and the leakage reactance is 0.012 ohm . Find the equivalent winding resistance, reactance and impedance referred to the low voltage side. [5+5]

OR

- 8.a) What are the merits and demerits of induction motor.
 b) A 10 -pole, 3 -phase induction motor runs at a speed of 485 rpm at 50 Hz supply. Determine i) synchronous speed and ii) slip. [5+5]
- 9.a) What is meant by synchronous speed? Explain why the speed of the induction motor never equal to be the synchronous speed.
 b) Explain the working principle of single phase induction motor. [5+5]
10. What are the disadvantages of low power factor? Discuss the improvement of low power factor. [10]

OR

- 11.a) Explain the MCB with neat diagram.
 b) Describe the elementary calculations for energy consumptions. [5+5]